



# Instructions for Use

## PhysioMem<sup>®</sup> PM 100 4G



### Tele-ECG Event Recorder

Revision 04 EN

Cardiac Diagnostics

Vital Signs Monitoring

Telemonitoring



# Contents

1	Information about this Manual.....	4
2	Intended Purpose .....	5
3	Indications and Contraindications .....	5
4	Regulatory information .....	6
5	Classifications.....	6
6	Labelling .....	7
7	Safety Information .....	9
7.1	Definitions.....	9
7.2	General Warning Notes.....	10
7.3	General Precautions.....	12
7.4	Incident Reporting.....	14
8	Warranty and Service Information.....	15
8.1	Maintenance and Repair .....	15
8.2	Cleaning and Disinfection .....	15
9	Operation.....	17
9.1	Operating elements.....	17
9.2	Visual and acoustic signals .....	18
9.3	Lead Scheme .....	21
9.4	Startup and Shutdown.....	21
9.5	Charging the Battery.....	23
9.6	How to apply the Device .....	26
9.7	Recording an ECG.....	28
9.8	Automatic Transmission .....	29
9.9	PhysioMem PM 100 4G and ReSTA.....	33
10	ECG Report.....	34
11	Patient Information.....	36
12	Disposal of Device and Accessories.....	37
13	Troubleshooting.....	38
13.1	Error Codes .....	38
13.2	Common Problems .....	39
14	Information regarding Consumables and Accessories .....	41
15	Specifications.....	42
15.1	PhysioMem PM 100 4G – General.....	42
15.2	Wireless Charging Pad – General.....	43
15.3	Operating conditions .....	43
15.4	Transport and Storage Conditions.....	44
15.5	Electromagnetic Compatibility (EMC).....	44
16	List of figures .....	50

# 1 Information about this Manual

This manual is published by:

GETEMED Medizin- und Informationstechnik AG  
Oderstr. 77, 14513 Teltow, Germany  
[www.getemed.de](http://www.getemed.de)

The information provided in this manual applies to PhysioMem PM 100 4G, version 2.x.x. It does not apply to earlier versions.

Adobe Acrobat and Reader are either registered trademarks or trademarks of Adobe Systems Incorporated in the United States and/or other countries.

PhysioMem is a trademark owned by GETEMED Medizin- und Informationstechnik AG.

Other company and product names mentioned herein are trademarks of their respective companies.

## Revision History

Revision	Publication Date	Description
01	2021-11-30	1st edition
02	2022-02-25	2nd edition - Cautions and symbols revised
03	2023-05-03	3rd edition – Updated description of the screens, the general specification and the ECG lead scheme
04	2023-09-22	4th edition – Updated description of the screens (recording)

## 2 Intended Purpose

The PM 100 device is a two-channel cardiac event recorder for transmitting multiple event recordings via cellular telephony networks to a compatible receiving system, such as ReSTA from GETEMED. The device is intended for patient activated recordings. The PM 100 is intended to be used in both home environments and clinical environments. Home environments include urban/suburban/ rural, school/office/retail environments, and vehicles like trains and cars. Airplanes are excluded as long as the use of cellular radio equipment is not allowed during flight. The device is battery-driven and utilizes a FLASH memory to store ECG data. The PM 100 is not intended to be used as a critical care monitoring system and should not be used in emergency situations.

## 3 Indications and Contraindications

The PM 100 is indicated for the diagnostic evaluation of adult and pediatric (over 10 kg body weight) patients with asymptomatic and symptomatic disturbances of the cardiac rhythm and for the evaluation of recurrent unexplained episodes of racing heart, syncope, palpitations or dizziness. Patients with an age of less than 14 years need support from adults.

The device is not indicated for patients whose clinical condition requires continuous monitoring of vital physiological parameters, where the nature of variations is such that it could result in immediate danger to the patient.

## 4 Regulatory information

# CE 0197

The CE Mark and Notified Body Registration Number signifies the device including its accessories meets all general safety and performance requirements of the Medical Device Regulation (EU) 2017/745.







The CE Mark also signifies the device including its accessories meets all essential requirements of the Radio Equipment Directive 2014/53/EU.







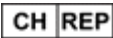

## 5 Classifications

MDR (EU) 2017/745 classification	Class IIa
Protection against electric shock	Type CF (Cardiac Floating), non-defibrillation-proof applied part
Mode of operation	Continuous
Method(s) of sterilization recommended by the manufacturer	Not applicable
Use classification	Multiple patients multiple use







## 6 Labelling

The following symbols appear on the device type label and / or on the packaging label:

Symbol	Description
PhysioMem	Device type
	Symbol "Model number identifier"
PM 100 4G	Model type
	Symbol "Serial number"
840 YY XXXXX	Serial number of device
	Symbol "Catalogue number"
77214001	Model catalogue (REF) number
 2021-11-30	Name and address of the manufacturer. Below the solid factory symbol is the date on which the device was manufactured. Next to the solid factory symbol is the name of the manufacturer.
	Symbol "Distributor" Next to the symbol is the name and the address of the distributor.
	Symbol "Country of origin" "DE" indicates that the product is made in Germany.
	Swiss representative
MADE IN GERMANY	Country of origin

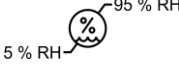
Symbol	Description
	CE marking, followed by the certification number of the Notified Body of the manufacturer.
	Symbol "Non ionizing radiation"
	Symbol "Applied part type" The symbol informs medical professionals that the device is classified as "cardiac floating" (CF) and that it is NOT protected against defibrillation.
	Symbol "Medical Device"
 LiPo 3.7 V / 880 mAh	Symbol "Rechargeable battery" The symbol indicates that the device is powered by a rechargeable battery.
IP64	The ingress protection classification of the device is IP64, whereby 6 = dust proof, 4 = protected against splashing water.
	This symbol indicates that you must dispose of the device properly. Further information is provided in the section "Disposal of Device and Accessories".
	Symbol "Unique Device Identifier"
 [01] 04250903202513 [11] 201121 [21] 8401400001 [241] 77214001	UDI Label; matrix code with GTIN [01], date of manufacturing [11], device identifier [SN] [21] and device catalogue number [REF] [241]



Symbol	Description
	Symbol "Read instructions for use" Read and understand the operator's manual before using the device.
	Temperature limits -20 °C ... 60 °C. Indicates the upper and lower temperature limits allowed for the device's storage and shipping.
	Humidity limitation 5 % ... 95 %. Indicates the upper and lower humidity limits allowed for the device's storage and shipping.
	Symbol "Fragile" Indicates the contents are fragile and should be handled with care.
	Symbol "Keep dry" Indicates that you need to keep the container away from rain and other sources of moisture.
	Symbol "Recycling" The packaging is capable of being recycled.

## 7 Safety Information

### 7.1 Definitions

The terms "Warning" and "Caution" are used in these Instructions for Use to indicate hazards and the degree of severity. A hazard is defined as a potential source of harm, harm being defined as injury or damage to the health of people, or damage to property or the environment.

**WARNING** indicates a potential hazard or unsafe practice which, if not avoided, could result in death or serious injury.

**CAUTION** indicates a potential risk or unsafe practice which, if not avoided, could result in minor personal injury or damage to the product or property.

**NOTICE** indicates application notes or other useful information to ensure that you get maximum benefit from the product.

## 7.2 General Warning Notes

### **WARNING** MIXING UP RECORDINGS

The patient's life or health may be put at risk if the patient is assigned a different patient's ECG recording thus resulting in an incorrectly assigned diagnosis.

Take special care to always select the correct examination and the correct patient.

Before the device is given to another patient, check that there are no more recordings stored on the device.

### **WARNING** STRANGULATION BY THE NECK LANYARD

Neck lanyards present a possible strangulation risk.

Do not wear the device with the neck lanyard around your neck while you are sleeping.

### **WARNING** RISK OF CONTAMINATION OR INFECTION

Device and accessories may be contaminated with bacteria or viruses after use.

If any contamination of the device or accessories has occurred, observe the standard procedures for handling contaminated objects and the following precautions:

- Use protective gloves to handle the equipment.
- Isolate the material by using suitable packaging and labeling.
- Contact the addressee before sending the equipment.
- Clean the device and accessories after every use.

- WARNING** NOT A MONITORING DEVICE  
The PhysioMem PM 100 4G is not a monitoring device and is not intended for monitoring the clinical condition of a patient.  
Do NOT use the PhysioMem PM 100 4G as a monitoring device.
- WARNING** EXPLOSION HAZARD  
Electrical sparks can cause explosions in the presence of certain gases.  
Do not use device in an oxygen-enriched environment or around other flammable or explosive gases. Establish whether the patient is liable to be in such an environment, possibly for job-related reasons.
- WARNING** MALFUNCTION OF PACEMAKERS AND ICD  
The device has an integrated mobile transmission module. Active mobile transmission devices in the close vicinity of pacemakers and implantable cardioverters/defibrillators (ICD) can cause malfunctioning of these devices. Do not place the device in the breast pocket of your shirt. Keep it at least 15 cm away from your implanted device after the recording. Patients with pacemakers or ICDs must not use the supplied neck lanyard to carry the device.
- WARNING** EXTREME TEMPERATURES  
The device performance may be compromised at extreme temperatures.  
If the device has been stored at a temperature close to the extreme hot or cold limit, wait at least 4 hours for the device to reach ambient temperature before use.
- WARNING** HOUSEHOLD PETS AND VERMIN  
Household pets and vermin may pose a risk to patient safety.  
Protect the device and accessories against contact with household pets, pests and children, as they could cause safety related damage to it, e.g., by biting it, letting it drop, exposing it to fluids or dirt.

## 7.3 General Precautions

- CAUTION**      ELECTROMAGNETIC EMISSIONS  
While acquiring data do not use mobile phones or other electrical equipment such as computers or electrical tools close to the device. That may cause interference.
- CAUTION**      ELECTROMAGNETIC EMISSIONS  
Switch off the device in locations where the use of mobile network devices is totally or at times forbidden (e.g., intensive care unit, airplane).
- CAUTION**      HUMID ENVIRONMENTS  
The temperature of the device must not go below 5 °C or above 45 °C. Do not expose the device to sudden temperature or humidity changes. Quick changes in temperature or humidity can cause condensation. Do not bring the device into the proximity of heat sources, such as heaters and ovens, and do not expose it to direct sunlight.
- CAUTION**      DAMAGE OF DEVICE AND ACCESSORIES  
Protect the device against mechanical damage by shocks, pressure and scratches. Otherwise, the correct functioning of the device can no longer be guaranteed.
- CAUTION**      DAMAGE OF DEVICE AND ACCESSORIES  
Do not use the device in the event of the packaging being damaged, unintentionally opened before use or if the packaging is exposed to environmental conditions outside of those specified in this manual. Otherwise, the correct functioning of the device can no longer be guaranteed.
- CAUTION**      MALFUNCTION  
Do not use the device if it has been damaged or has malfunctions.

- CAUTION**      **UNAUTHORIZED ACCESS**  
In order to avoid a wrong assigning of ECG data, keep the device protected against unauthorized access by third persons.
- CAUTION**      **CONDUCTIVITY**  
When wearing the device, ensure that the electrodes do not contact other conductive parts including earth.
- CAUTION**      **PROPER MAINTENANCE**  
Proper maintenance is vital for long-term safety and reliability of the device. Each time before giving the device to a patient, visually check the device for damage.
- CAUTION**      **SERVICE AND REPAIR**  
Repairs must be carried out only by persons authorized by the manufacturer. If you find or even suspect a malfunction, send the device for testing to the manufacturer or a facility authorized by the manufacturer. Please add a detailed description of the observed malfunction.
- CAUTION**      **APPROVED ACCESSORIES**  
Safe and reliable operation of the device is only possible when using the supplied and approved accessories.
- CAUTION**      **INFECTION RISK**  
Returning parts and products that have not been disinfected exposes our service personnel to a risk of infection. For hygienic reasons, and especially to help protect our service personnel, please disinfect the device before returning them to us for inspection or maintenance.
- CAUTION**      **ACCIDENTAL ACTIVATION**  
If the device is not in use, switch it off and store it with care to prevent accidental activation. This could result in incorrect ECG interpretation. Also, switch off the device before shipping to prevent inadvertent data transmission.

## **7.4 Incident Reporting**

Any serious incident that has occurred in relation to the device should be reported to the manufacturer and to the competent authority.

A serious incident is a device malfunction that results in death or serious injury, or may lead to death or serious deterioration in state of health of an individual.

## 8 Warranty and Service Information

### 8.1 Maintenance and Repair

The device does not require any special maintenance to maintain its safety and performance features during the expected life-time.

Only authorized personnel are allowed to repair the device. Any unauthorized attempts to repair the device will make any warranty claims null and void. It is the operator's responsibility to report the need for repair to the manufacturer or one of his authorized representatives. If you determine or suppose any malfunction, send the device for checking to the address specified below. Please add a detailed error description.

If you determine an unexpected operational condition or unexpected occurrences or if you need technical support, contact the manufacturer under the following address:

GETEMED Medizin- und Informationstechnik AG  
Oderstr. 77, 14513 Teltow, Germany  
[www.getemed.de](http://www.getemed.de)

### 8.2 Cleaning and Disinfection

Clean and disinfect the device at regular intervals, prior to first use and before passing it on to another person.

#### **CAUTION**

Do not use solvents, such as ether, acetone or paraffin oil; such substances can damage the material of the housing.

#### **CAUTION**

Do not submerge the device and the Wireless Charging Transmitter Pad or allow fluid to enter the device and the Wireless Charging Transmitter Pad under any circumstances.

## CAUTION

Do not sterilize the device or accessories.

Switch off the device before cleaning and/or disinfection. Before performing surface disinfection, clean the device. Use a lint-free cloth slightly moistened with a mild soap solution to wipe the device.

GETEMED recommends to use a 70 % alcohol solution for disinfection. Please note the application time of the disinfectant (10 minutes for 70 % alcohol solution). Subsequently use a lint-free cloth slightly moistened to remove remainders of the disinfectant.

The device withstands up to 700 cleaning / disinfection cycles (7 years of normal use). Re-processing by way of a machine is excluded for the product.

The product is not intended for sterilization. Store re-processed products in a dust-free and dry place.

The instructions listed above have been validated by the medical device manufacturer as being suitable for preparing the medical device for reuse. It is the responsibility of the processor to ensure that the processing actually carried out with the equipment, materials and personnel used in the processing facility achieves the desired result. This requires verification and / or validation and routine monitoring of the process.



## 9 Operation

### 9.1 Operating elements

On the front side the device features a pushbutton (1) for switching on / off and for starting a recording, and a display (2) for the indication of operating modes and error codes. The pushbutton is marked with the symbol  (Figure 1).

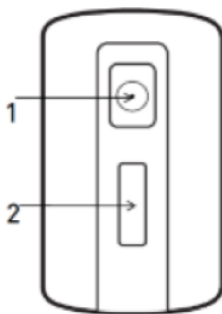

Figure 1 - Pushbutton and display









The four electrodes for the ECG lead are positioned on the back of the device (Figure 2).







Figure 2 - Electrodes





## 9.2 Visual and acoustic signals

The following symbols can be displayed:

Cellular radio is switched on, not connected, searching for network	
Device is attached to mobile network, signal strength	
Device connected to ReSTA server, signal strength	
Number of ECG in memory	
Data transmission failure	
Battery state - 20 %, 40 %, 60 %, 80 %, 100 % capacity	
Charging of the battery required - recording possible, transmission not possible until the battery is recharged until 20 % capacity	
Battery exhausted. Recording not possible until the battery is recharged until 20 % capacity	

The device states are indicated by way of symbols on the display and acoustic signals:

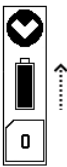
Device State	Display	Buzzer
Device is starting		1 x beep
Device is switching off		-
Status message is being transmitted		-
Device is ready for recording (cellular radio is switched off, no data stored in the device memory, battery is fully charged)		-
Button pressed (recording started)	-	1 x beep
Recording in progress	-	1 single beep on every recognized heart beat

Device State	Display	Buzzer
Recording finished, transmission starts		Rising sequence of 4 x short beeps
Automatic transmission of one ECG in progress, device is searching for cellular network		-
Automatic transmission of one ECG in progress, device connected to ReSTA server		-
Battery charging has started	-	2 x short beep
Battery charging in progress (battery symbol is changing)		-
Error (see section "Troubleshooting" in this manual for more information)		3 x short beep

### 9.3 Lead Scheme

The device uses four electrodes to acquire a two channel ECG (Figure 3).

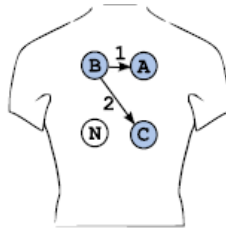

Figure 3 - Lead Scheme

Channel 1: B → A

Channel 2: B → C

### 9.4 Startup and Shutdown

The device can be switched on / off by means of the pushbutton. Press the pushbutton briefly to switch on the device. The display shows the startup screen (Figure 4).

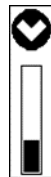

Figure 4 - Startup Display

When the startup process has finished the device establishes a connection to the ReSTA server and sends a status message that contains the memory and battery status (Figure 5).

Settings, date and time are synchronized with the ReSTA server.

## NOTICE

The initial communication should not be interrupted if the device has not been used for a longer period of time in order to ensure proper time synchronization.



Figure 5 - Status message

Once the device is ready for use, the display shows the status screen (Figure 6).

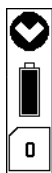

Figure 6 - Status screen

The device can be switched off by pressing the button for longer than 10 seconds. The display shows the power off screen (Figure 7).



Figure 7 - Power off screen

## NOTICE

Ensure that the device is always ready for use and only switch it off if you will not use it for a longer time, e. g. on an airplane or if a reset becomes necessary.

**NOTICE**

Use the storage pouch supplied for safe storing of the device when not in use.

**NOTICE**

Switch off the device if this is not to be used for some time.

**NOTICE**

Check the charging state of the device if it has not been used for some time and charge the device as explained in this manual.

**NOTICE**

Always switch off the device prior to any shipping and only ship it in the storage pouch and in the packaging supplied.

## 9.5 Charging the Battery

The device has a built-in rechargeable battery, which is charged by inductive coupling with the Wireless Charging Transmitter Pad (charging pad). Before first use of the device, the battery has to be fully charged.

Charging the battery after complete discharge takes approx. 3 hours. A fully charged battery lasts approx. 5 days in typical use (3 ECG recordings per day).

Use the USB cable to connect the charging pad to the power adaptor and connect the power adaptor to the mains supply.

The green LED is shining as soon as the charging pad is connected to the power supply system (Figure 8).

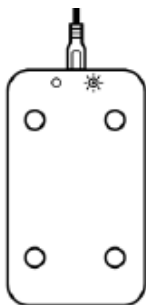

Figure 8 - Charging Pad is power on

Place the device's electrodes in the cavities on the charging pad in order to position the device properly (Figure 9).



Figure 9 - Device placed on the Charging Pad

The charging process starts automatically. It is possible to charge the device even if it is switched off.

If the device is switched on the display of the device indicates that the charging is in progress (Figure 10).

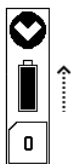

Figure 10 - Device display - Charging in progress

A short double beep will sound once the device is placed on the charging pad. The short double beep will also sound if the device is switched on while it is on the charging pad. The orange LED



and the green LED on the charging pad are shining if the battery is being charged (Figure 11).

If the device is put on the charging pad and the battery has been fully charged to 100 % already the double beep does not sound and the orange LED is not shining.

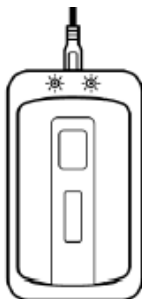

Figure 11 - Charger Pad - Charging in progress

If the battery of the device has been fully charged the orange LED switches off and only the green LED is shining (Figure 12).



Figure 12 - Charger Pad - not charging

#### **NOTICE**

If the ambient temperature is lower than 0 °C the device should not be charged.

## **NOTICE**

If the orange LED flashes after the device has been placed on the charging pad an error with the charging process has occurred. Disconnect the charging pad from the power supply and reconnect it.

Inform the service of the manufacturer if the orange LED continues to flash

## **NOTICE**

Even during charging you can take the device from the charging pad and use it for a recording.

## **NOTICE**

Disconnect the power plug from the network connector if the charging pad is not used. Make sure that you always have access to the power network connector.

## **NOTICE**

The cellular communication is blocked when the device is in charging mode.

In case of unsend recordings, the communication will be restarted once the charging process is finished.

## **9.6 How to apply the Device**

The ECG electrodes are integrated like little feet in the back of the device. Make sure that all four electrodes have skin contact and that there are no pieces of clothing or other items between electrode and skin.

The manufacturer recommends always wearing the device by means of the included neck lanyard. In this way, no time is lost when an ECG is to be recorded.

## WARNING

**MALFUNCTION OF PACEMAKERS AND ICD** – Patients with pacemakers or ICDs must not use the supplied neck lanyard to carry the device.

Attach each of the two loops to the attachment holes (1) of the device (2) and connect the neck lanyard to the clips on the loops. Finally adjust the length of the neck lanyard to suit your needs (Figure 13).

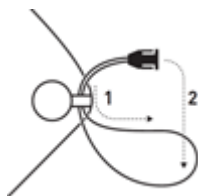

Figure 13 - Attaching the Neck Lanyard

Position the device on the middle of your sternum. Make sure that there is no clothing between electrodes and skin (Figure 14).



Figure 14 - Device positioned on the chest

## WARNING

**STRANGULATION BY THE NECK LANYARD** – Neck lanyards present a possible strangulation risk. Do not wear the device with the neck lanyard around your neck while you are sleeping.

## 9.7 Recording an ECG

Take an upright sitting posture and breathe calm before you start the recording. Hold the device steady and press the four electrodes firmly on the chest. Then press the pushbutton to start the recording (Figure 15)



Figure 15 - Starting the recording

The display is switched off during recording and every detected heartbeat (R-R') is indicated acoustically by a short beep.

The recording duration is 40 seconds. During this time, breathe steady, refrain from jerky body movements and avoid changing the device position on the chest.

Once the recording is finished the device sounds a rising sequence of 4 x short beeps.

The device also detects if an electrode has no skin contact (open lead). The heart beat will not be detected anymore and the beep sound stops if this happens. The beep does not sound until all four electrodes have skin contact again. When the beep fails during recording carefully correct the position of the device and press it more firmly on the chest. In case of strong chest hair shortly move the device back and forth so that no hair obstructs the contact between electrodes and skin. Skin contact of the electrodes can be impaired when the skin is too dry. Moisten the electrodes with a little water when the skin is dry and there is no beep.

## NOTICE

An irregular beep during recording does not necessarily indicate a cardiac arrhythmia. Usually this is caused by motion artifacts.

## NOTICE

Recording is not possible if the battery is exhausted. This is indicated in the display when the button is pressed to start a recording (Figure 16).

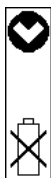

Figure 16 - Battery exhausted

## 9.8 Automatic Transmission

### WARNING

**MALFUNCTION OF PACEMAKERS AND ICD** – Patients with pacemakers or ICDs must not place the device in the breast pocket of their shirt and must keep it at least 15 cm away from their implanted device after the recording. Patients with pacemakers or ICDs must not use the supplied neck lanyard to carry the device.

Immediately after recording the device automatically starts the transmission of the recorded ECG data. The device activates the cellular radio, establishes a connection to a mobile network and then transmits the recorded data to the ReSTA server. The transmission progress is indicated on the display (Figure 17).

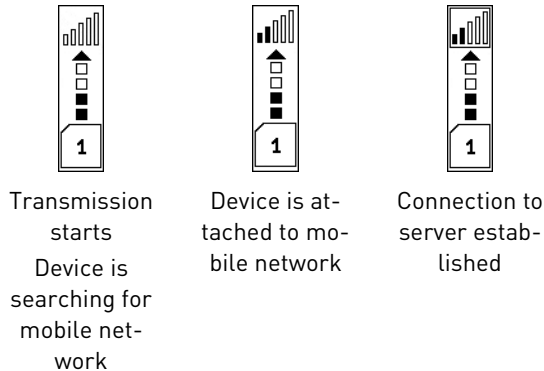

Figure 17 - Automatic Transmission

The duration of the transmission depends mainly on the number of ECG recordings to be transmitted. The transmission of a single ECG can take up to three minutes.

Once an ECG recording was successfully sent it is deleted from the device memory. The display shows the number of remaining recordings.

The cellular radio is switched off automatically when the transmission has finished.

If the transmission of one or several ECG fails the transmission will be repeated automatically at the following time intervals until the transmission is successful or a new recording has started.

- 1st attempt immediately after the failed transmission
- Three attempts every 15 minutes
- One attempt after 5 hours
- Further attempts every 24 hours

A new recording can be started anytime during a transmission already in progress. In this case the transmission will be interrupted. The ECG recording remains in the memory until the next transmission.

## **NOTICE**

It is not possible to establish a connection to a mobile network manually.

## **NOTICE**

Depending on the availability of the GSM or other networks (e.g., the Internet), the transmission of the data can be delayed.

## **NOTICE**

If the ECG data cannot be transmitted for a longer time e.g., because of poor mobile network coverage it is recommended to change the location of the device (e.g., go outdoors, change the side of the street, etc.).

## **NOTICE**

The automatic connection to a public mobile network could result in previously unidentified risks to patients, users and third parties. The responsible organization must identify, analyze, evaluate and control these risks.

Changes to the network, such as:

- Changes in the configuration of the network
- Connection of additional components
- Disconnection of components from the network
- Update of components connected to the network

could cause new risks that require additional analysis. Refer to the standard EN 80001.



## 9.9 PhysioMem PM 100 4G and ReSTA

ReSTA is a server-based software for receiving and transmitting ECG data (Figure 18).

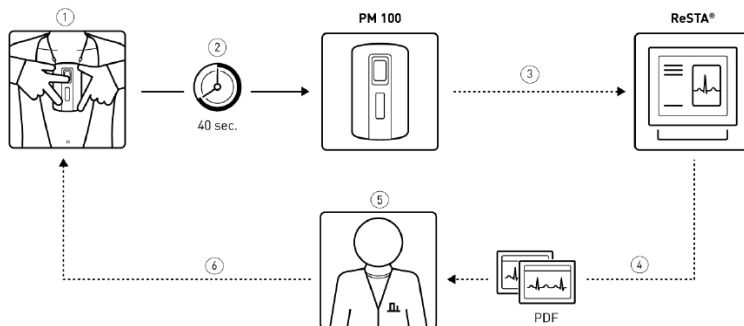

Figure 18 - PhysioMem PM 100 4G and ReSTA

In ReSTA the device ID of each PhysioMem PM 100 4G is assigned to a corresponding target address (email, URL). The patient (1) makes a recording (2) that will be transmitted automatically to the ReSTA server via mobile network (3). The data will be forwarded via internet (4) to the defined target address of a medical facility (5) for analysis and review with the patient (6).

The target address can be changed on request of the device owner.

### CAUTION

The attending physician or medical facility as receiver of ECG data has to ensure that these ECG data are assigned to the corresponding patient.

### NOTICE

No patient-related information is stored on the PhysioMem PM 100 4G or in ReSTA. Only the responsible medical facility knows the identity of the patient.

# 10 ECG Report

## WARNING

To evaluate ECG reports, use the software “Adobe Reader” in the latest version. If you use a different PDF viewer software, accurate display cannot be guaranteed.

The ECG report consists of two pages in landscape format and includes all relevant ECG and device information (Figure 19).

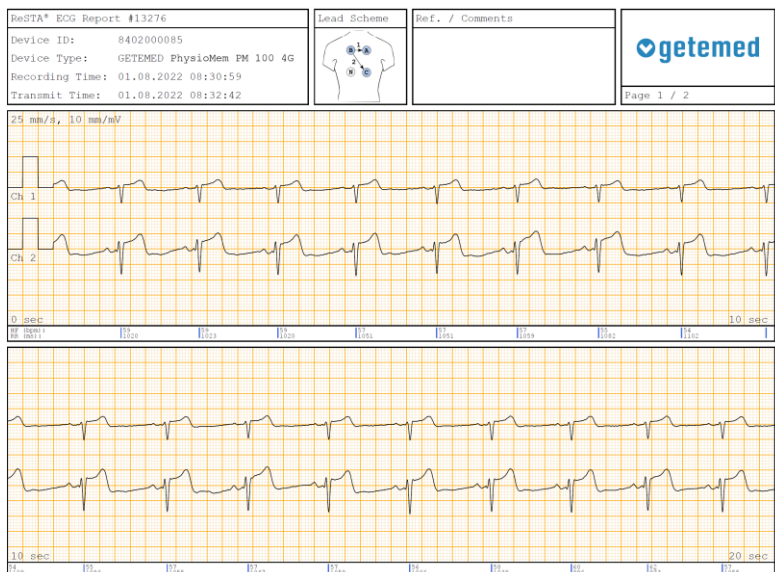

Figure 19 - ECG Report

The header of the report contains information about the device used and the recording and transmission times.

The two-channel ECG is presented in four stripes of 10s each with a recording speed of 25 mm/s and an amplitude of 10 mm/mV.

The heart rate in beats per minute [bpm] and [ms] is continuously calculated from the time that elapses between two consecutive beats. Averaging is not used for the calculation.

**NOTICE**

The accuracy of the heart rate readings depends on the ECG signal quality. The heart rate readings can be inaccurate if the ECG signal is noisy.

**NOTICE**

The device is not indicated to detect pauses automatically.

**NOTICE**

The recording and transmission times refer to Central European Time or Central European Summer Time (CET or CEST).

**NOTICE**

In case of loss of the device immediately contact your distributor or the manufacturer.

# 11 Patient Information

It is the responsibility of the medical professional to provide the patient with the following information required for safe use of the device.

## Safety

The patient must observe the warnings and precautions in this manual, as indicated by symbol ISO 7010-M002 - "Refer to instruction manual" attached to the device.

## Operation

Instruct the patient how to

- Recharge the device,
- Switch the device on and off,
- Record an ECG including proper application / positioning of the device on the patient's chest.

Inform patients with pacemakers or ICDs about precautions to be taken in order to avoid malfunction of the implanted device.

## Recording Diary

It is recommended having the patient maintain a diary to record activities, symptoms and the corresponding times so that this information can be linked to the recordings later on. The header of the diary should include data required to identify the patient, the recording, and the medication taken during the recording.

## Medical Emergency

The device is not intended to detect life-threatening events. Instruct the patient to call a doctor or emergency services immediately if he/she feels unwell in the state of his/her health.

## 12 Disposal of Device and Accessories

Electrical devices contain metal and plastic parts. To avoid environmental damage, the device and its accessories must only be disposed of in accordance with the relevant disposal directives at the end of their service life.



If you have any questions regarding the disposal of the product, do not hesitate to contact the manufacturer or its representatives.





# 13 Troubleshooting

## 13.1 Error Codes

<b>Error Code</b>	<b>Cause</b>	<b>Remedy</b>
E01-E05	Internal system error.	Contact the service of the manufacturer.
E06	SIM card not activated or SIM card suspended.	Contact the service of the manufacturer.
E07	Real time clock failure.	Restart the device. Press the button until the device is power off. Then press the button to restart the device. If a restart does not solve the problem, contact the service of the manufacturer.
E10	The operating temperature of the device is too high or too low. In this case, the device switches off automatically after 30 seconds.	Only switch the device on again in an ambient where the temperature is within the range of the operating temperature.
E12	ECG module failure.	Contact the service of the manufacturer.
E13	Internal power failure.	Contact the service of the manufacturer.
E14	Memory failure.	Restart the device. Press the button until the device is power off. Then press the button to restart the device. If a restart does not solve the problem, contact the service of the manufacturer.

## 13.2 Common Problems

Symptom	Cause	Remedy
Battery cannot be charged - the green LED on the charging pad is not shining.	The Charging pad is not connected to mains supply.	Connect the USB cable to charging pad and to the power adaptor. Then connect the power adaptor to the mains supply.
Battery cannot be charged - the green LED on the charging pad is shining, the orange LED is not shining.	The Device is not positioned correctly on the charging pad.	Correct the position of the device on the charging pad. A beep sounds when the charging process starts and the orange LED is shining.
The orange LED flashes after the device has been placed on the charging pad.	An error with the charging process has occurred.	Disconnect the charging pad from the power supply and reconnect it. Inform the service of the manufacturer if the orange LED continues to flash
ECG data cannot be transmitted.  	No mobile network connection.	Data transmission will be repeated automatically. If necessary, change location.
ECG data cannot be transmitted but mobile network connection has been established.	Device has not been activated by the manufacturer.	Contact the service of the manufacturer.

Symptom	Cause	Remedy
Symbol  displayed	Data transmission failure.	Record a new ECG and check if the problem is solved. Otherwise contact the service of the manufacturer.
ECG data cannot be transmitted. 	Battery capacity below 20 %.	Recharge the battery. The transmission will be repeated automatically.
ECG recording not possible. 	Battery exhausted.	Recharge the battery. Recording is possible when the battery symbol turns to the normal battery status.
ECG recording not possible. 	Memory occupied.	Data transmission is repeated automatically. If necessary, change location.
No display / irregular Display.	Malfunction possibly caused by strong electromagnetic interference.	Switch off the device and switch it on again. Check the operation environment for sources of strong electromagnetic fields.



## 14 Information regarding Consumables and Accessories

<b>Part</b>	<b>REF number</b>
PhysioMem PM 100 4G Tele ECG Event Recorder	77214001
Wireless Charging Transmitter Pad	77442301
Power supply for wireless charging transmitter pad	77441101
USB cable for wireless charging transmitter pad	77412001
Neck lanyard	77451001
Bag	77451002
Operating Manual English	77814021
Patient's Guide German/English	77821011
Packaging	77900001

# 15 Specifications

## 15.1 PhysioMem PM 100 4G – General

<b>Recording channels</b>	2 channels
<b>ECG leads</b>	2 leads, 4 metal electrodes
<b>Recording time</b>	40 s (default), 60 s, 90 s, 120 s
<b>Lead off detection</b>	Yes
<b>Pacemaker detection</b>	No
<b>Display</b>	1 LCD display
<b>Buttons</b>	1 button
<b>Recording method</b>	Digital memory, non-removable
<b>Transmission method</b>	Wireless GSM
<b>Memory</b>	200 ECG episodes
<b>Battery</b>	3,7 V / 880 mAh Lithium-Polymer, rechargeable
<b>Battery lifetime</b>	5 days (recording and transmission of 3 ECGs per day)
<b>Expected service life</b>	5 years
<b>Sampling rate</b>	1024 / s
<b>A/D converter</b>	24 Bit
<b>Input voltage range</b>	+/- 6 mV
<b>Input impedance</b>	> 10 MOhm
<b>Dimensions</b>	114 mm x 68 mm x 18 mm
<b>Weight</b>	107 g
<b>Material</b>	ABS
<b>Degree of protection</b>	IP 64
<b>Application time (typ.)</b>	4 weeks

<b>Transmission technology</b>	LTE Cat M1 and NB1; EGPRS
<b>Transmission frequency</b>	LTE: B1 (2100 MHz), B3 (1800 MHz), B8 (900 MHz), B20 (800 MHz), B28 (700 MHz); GSM: B8 (900 MHz), B3 (1800 MHz)
<b>RF Output transmission power</b>	23 +/-2 dBm

## 15.2 Wireless Charging Pad – General

<b>Dimensions</b>	145 mm x 84 mm x 9 mm
<b>Weight</b>	50 g
<b>Input voltage</b>	5 VDC
<b>Degree of protection</b>	IP 21
<b>Operation Frequency</b>	109.39 kHz ... 174.3 kHz
<b>Max. RF power transmitted</b>	-8.12 dBμA / m @ 10 m

## 15.3 Operating conditions

<b>Temperature range</b>	5 °C ... 45 °C
<b>Relative humidity</b>	10 % ... 95 %, non-condensing
<b>Ambient pressure</b>	106 kPa ... 50 kPa 106 kPa ... 80 kPa (power supply)

## 15.4 Transport and Storage Conditions

<b>Temperature range</b>	-20 °C ... 60 °C
<b>Relative humidity</b>	5 % ... 95 %, non-condensing
<b>Ambient pressure</b>	106 kPa ... 50 kPa

## 15.5 Electromagnetic Compatibility (EMC)

Medical electrical equipment needs special precautions regarding electromagnetic compatibility (EMC) and needs to be installed and put into service according to EMC information provided in this document.

### Guidance and manufacturer's declaration - electromagnetic emissions

This device is intended for use in the electromagnetic environment specified below. The customer or the user of the device should assure that the device is used in such an environment.

<b>Emissions test</b>	<b>Compliance</b>	<b>Electromagnetic environment - guidance</b>
RF emissions CISPR 11	Group 2	The device must emit electromagnetic energy in order to perform its intended function. Nearby electronic equipment may be affected.
RF emissions CISPR 11	Class B	The device is suitable for use in all establishments, including domestic establishments and those directly connected to the public low-voltage power supply network that supplies buildings used for domestic purposes.
Harmonic emissions IEC 61000-3-2	Class A	
Voltage fluctuations / Flicker emissions IEC 61000-3-3	Complies	

## Guidance and manufacturer's declaration - electromagnetic immunity (line-bound disturbances)

This device is intended for use in the electromagnetic environment specified below. The customer or the user of the device should assure that the device is used in such an environment.

Immunity test	IEC 60601-1-2 test level*	Compliance level*	Electromagnetic environment - guidance
Electrostatic discharge (ESD) IEC 61000-4-2	± 8 kV contact ± 15 kV air	± 8 kV contact ± 15 kV air	Floors should be wood, concrete, or ceramic tile. If floors are covered with synthetic material, the relative humidity should be at least 30 %.
Electrical fast transient/burst IEC 61000-4	+/- 2 kV for power supply lines +/- 1 kV for input / output lines	+/- 2 kV for power supply lines +/- 1 kV for input / output lines	Mains power quality should be that of a typical commercial or hospital environment.
Surge IEC 61000-4-5	+/- 1 kV differential mode	+/- 1 kV differential mode	Mains power quality should be that of a typical commercial or hospital environment.
Voltage dips on power supply input lines IEC 61000-4-11	0 % UT; 0,5 cycle At 0°, 45°, 90°, 135°, 180°, 225°, 270° and 315°	0 % UT; 0,5 cycle At 0°, 45°, 90°, 135°, 180°, 225°, 270° and 315°	Mains power quality should be that of a typical commercial or hospital environment. If the user of the device requires continued operation during power mains interruptions, it is recommended that the device be powered from an uninterruptible power supply or a battery.
	0% UT; 1 cycle and 70 % UT; 25/30 cycles Single phase: at 0°	0% UT; 1 cycle and 70 % UT; 25/30 cycles Single phase: at 0°	

Immunity test	IEC 60601-1-2 test level*	Compliance level*	Electromagnetic environment - guidance
Voltage interruptions on power supply input lines IEC 61000-4-11	0 % UT; 250/300 cycle	0 % UT; 250/300 cycle	
Power frequency (50/60 Hz) magnetic field IEC 61000-4-8	30 A/m	30 A/m	Power frequency magnetic fields should be at levels characteristic of a typical location in a typical commercial or hospital environment.

### Guidance and manufacturer's declaration - electromagnetic immunity (Conducted and radiated RF disturbances)

This device is intended for use in the electromagnetic environment specified below. The customer or the user of the device should assure that the device is used in such an environment.

Immunity test	IEC60601-1-2 test level*	Compliance level*	Electromagnetic environment - guidance
Conducted RF IEC 61000-4-6	3 V effective value 150 kHz to 80 MHz	3 V effective value	Portable and mobile RF devices are not used at closer than 30 cm to the device including leads
	6 V effective value in the ISM bands between 0,15 MHz and 80 MHz	6 V effective value in the ISM bands according to table 5, Note N	The field strength of stationary radio transmitters is, as determined by an electromagnetic site survey, at all frequencies smaller than the compliance level.
Radiated RF IEC 61000-4-3	10 V/m 80 MHz to 2,7 GHz Immunity against wireless RF communication devices	10 V/m according to table 9**	Interference may occur in the vicinity of equipment marked with the following symbol: 

\*) = Specifications according to IEC 60601-1-2: 2014

## NOTICE

These guidelines may not apply in all situations. Electro-magnetic propagation is affected by absorption and reflection from structures, objects and people.

\*\*] IEC 60601-1-2: 2014, table 9:

Test frequency (MHz)	Band a) (MHz)	Service a)	Modulation b)	Max. Power (W)	Distance (m)	Immunity test level (V/m)
385	380 – 390	TETRA 400	Pulse modulation b) 18 Hz	1,8	0,3	27
450	430 – 470	GMRS 460, FRS 460	FM c) ± 5 kHz deviation 1 kHz sine	2	0,3	28
710 745 780	704 – 787	LTE Band 13,17	Pulse modulation b) 217 Hz	0,2	0,3	9
810 870 930	800 – 960	GSM 800/900, TETRA 800, iDEN 820, CDMA 850, LTE Band 5	Pulse modulation b) 18 Hz	2	0,3	28
1720 1845 1970	1700 – 1990	GSM 1800; CDMA 1900; GSM 1900; DECT; LTE Band 1, 3, 4, 25; UMTS	Pulse modulation b) 217 Hz	2	0,3	28

Test frequency (MHz)	Band a) (MHz)	Service a)	Modulation b)	Max. Power (W)	Distance (m)	Immunity test level (V/m)
2450	2400 – 2570	Bluetooth, WLAN, 802.11 b/g/n, RFID 2450, LTE Band 7	Pulse modulation b) 217 Hz	2	0,3	28
5240 5500 5785	5100 – 5800	WLAN 802.11 a/n	Pulse modulation b) 217 Hz	0,2	0,3	9

## NOTICE

If necessary to achieve the IMMUNITY TEST LEVEL, the distance between the transmitting antenna and the ME EQUIPMENT or ME SYSTEM may be reduced to 1 m. The 1 m test distance is permitted by IEC 61000-4-3.

- a) For some services, only the uplink frequencies are included.
- b) The carrier shall be modulated using a 50 % duty cycle square wave signal.
- c) As an alternative to FM modulation, 50 % pulse modulation at 18 Hz may be used because while it does not represent actual modulation, it would be worst case.

## WARNING

Use of this equipment adjacent to or stacked with other equipment should be avoided because it could result in improper operation. If such use is necessary, this equipment and the other equipment should be observed to verify that they are operating normally.



**WARNING**

Use of accessories, transducers and cables other than those specified or provided by the manufacturer of this equipment, could result in increased electromagnetic emissions or decreased electromagnetic immunity of this equipment and result in improper operation.

**WARNING**

Portable RF communications equipment (including peripherals such as antenna cables and external antennas) should be used no closer than 30 cm to any part of the device, including cables specified by the manufacturer. Otherwise, degradation of the performance of this equipment could result.

# 16 List of figures

Figure 1 - Pushbutton and display .....	17
Figure 2 - Electrodes .....	17
Figure 3 - Lead Scheme .....	21
Figure 4 - Startup Display .....	21
Figure 5 - Status message .....	22
Figure 6 - Status screen .....	22
Figure 7 - Power off screen.....	22
Figure 8 - Charging Pad is power on .....	24
Figure 9 - Device placed on the Charging Pad .....	24
Figure 10 - Device display - Charging in progress.....	24
Figure 11 - Charger Pad - Charging in progress .....	25
Figure 12 - Charger Pad - not charging .....	25
Figure 13 - Attaching the Neck Lanyard.....	27
Figure 14 - Device positioned on the chest .....	27
Figure 15 - Starting the recording .....	28
Figure 16 - Battery exhausted.....	29
Figure 17 - Automatic Transmission .....	30
Figure 18 - PhysioMem PM 100 4G and ReSTA .....	33
Figure 19 - ECG Report .....	34



CE 0197



REF 77814021

Revision 04 EN / 2023-09-22



GETEMED

Medizin- und Informationstechnik AG

Oderstr. 77 / 14513 Teltow / Germany

Telephone: +49 (0)3328 / 3942- 0

Telefax: +49 (0)3328 / 3942-99

info@getemed.de / www.getemed.de